



MODIFIED RULES

NOTE: WHITTEMORE SPEEDWAY DOES NOT EXPRESS OR IMPLY ANY WARRANTY OF SAFETY RESULTING FROM THE PUBLICATION OF, OR COMPLIANCE WITH THESE RULES AND/OR REGULATIONS. THESE RULES ARE INTENDED AS A GUIDE TO CONDUCT OF THIS SPORT AND ARE NOT IN ANY WAY A GUARANTEE AGAINST INJURY OR DEATH TO ANY PARTICIPANT, SPECTATOR, OR OFFICIAL. THE ABSENCE OF A PARTICULAR RULE DOES NOT NECESSARILY MEAN ITS APPROVAL! ANY INFRACTIONS OF THE RULES MAY RESULT IN A WEIGHT PENALTY (FOR THAT EVENT) OR NOT BEING ABLE TO COMPETE ENTIRELY.

ALL IDENTIFIED RULE INFRACTIONS MUST BE RESOLVED PRIOR TO THE FOLLOWING EVENT (NO ON-GOING WEIGHT PENALTY SUBSTITUTE). ARGUING/ABUSING A RACE OFFICAL WHILE DOING THEIR JOB IS SUBJECT TO SUSPENSION FOR UNSPORTSMAN LIKE ACTIONS DETRIMENTAL TO THE SPORT.

1. SAFETY EQUIPMENT

- A. Snell-rated SA**2015** or newer helmet required.
- B. Roll bar padding required in drivers' compartment. (FIRE RETARDANT IS HIGHLY RECOMMENDED.)
- C. SFI full fire suit required. Fire retardant neck brace, gloves and shoes required. (FIRE RETARDANT HEAD SOCK AND UNDERWEAR; HEAD AND NECK RESTRAINTS AND COLLAPSIBLE STEERING SHAFT ARE HIGHLY RECOMMENDED.)
- D. Driver side window net required and **MUST** be mounted so that the latch is at the top front of window.
- E. A type of neck collar is mandatory.
- F. Seat belt minimum is 3" if a conventional type neck collar is being used. if a HANS device or similar head and neck restraint is being used where the seat belt shoulder straps go over the platform of the head and neck restraint you will be allowed the use of a 3/2/3 seat belt system which consist of 2" shoulder straps that pass over the head & neck restraint platform all other belts are 3" seat belts can be used up to maximum age of 5 years. Seat belts must be in good condition and free of cuts or tears, grinder marks, weld splatter, melted areas, extremely sun

faded or areas that are rough and extremely weathered. If any of the poor conditions are visible with your seat belts they will not be allowed for use.

- G. Fire Bottle system required. (A SEPARATE, HEAT ACTIVATED, FIRE BOTTLE ON THE FUEL CELL IS HIGHLY RECOMMENDED.)
- H. Kill switch required within easy reach of the driver and must be clearly marked 'OFF' and 'ON.'
- I. There must be a full shut off valve at the fuel tank.

2. DRIVER COMPARTMENT

- A. Minimum Aluminum racing seat bolted in securely, inside the left OEM frame rail. (NASCAR STYLE RIGHT AND LEFT HEAD, SHOULDER SUPPORTS AND LEG RESTRAINTS HIGHLY RECOMMENDED).
- B. Driver must be sealed off from track, driveline, engine, fuel cell, battery, and pumps.
- C. No driver adjustable devices allowed in cockpit except brake adjusters.
- D. A 1 way receiver "Raceiver" tuned to track frequency (454.00) must be used with radios if you choose to use a 2 way communication Radio.
- E. Electronics: No cell phones, smart phones, smart watches, laptop computers or tablets allowed in vehicle or with driver and will be an automatic disqualification.

3. FRAME

- A. A. Steel OEM perimeter American made rear wheel drive passenger car frame only. (Reproduction 68-72 Chevelle frames are approved.) No sports car frames allowed.
- B. Howe fab / tube mod clip/frame is the only tube clip allowed - i.e. Chevelle, and Big GM Metric clips are legal at Whittemore Speedway -Must conform without deviation to Manufacturer supplied certified template upon inspection.(no weight penalty for the Howe tube mod front clip/frame)
- C. Oem Ford frame with strut style front suspension is allowed, (a tube reproduction for the ford strut style front suspension is not allowed)
- D. Frame must be full and complete, cannot be widened or narrowed, and must be able to support roll cage on both sides.
- E. A Camaro front sub frame tube or OEM attached to OEM frame rails is not allowed.

Exceptions:

1. Weight jack located in the original centerline of the spring tower.
2. Frame may be cut a maximum 36" forward from the center of rear housing.
3. Horns may be removed in front or flush with steering box
4. Front cross-member may be notched and boxed for radiator and/or steering clearance
5. 7-10" maximum opening on side of spring tower for spring removal.
6. OEM upper A-frame mounts may be replaced with aftermarket mounts.
7. Maximum 4" x 4" tall frame stiffener may be welded directly to the outside of the left OEM frame rail.

8. Left side OEM frame rail may be notched within the cockpit for safety and foot clearance.
9. Right side frame rail must have the top and bottom of the frame (No lightening of frame rail).
10. Seat must be mounted between stock frame rails.
11. Wheelbase will be between 108" and 112" on both sides.
12. Maximum overall track width, front and rear, shall not exceed 78" from outside of tire, to outside of tire measured at spindle pin height

4. ROLL CAGE:

- A. Must consist of continuous hoops, minimum 1.75" O.D. tubing, with a minimum wall thickness of .095" for the main cage.
- B. Frame must be mounted in at least 6 places, low carbon, or mild steel recommended.
- C. Roll cage must consist of a configuration of front, rear, and top hoops connected by tubing on the sides or side hoops.
- D. Driver's head must not protrude outside or above cage with helmet on.
- E. Roll cage must be securely supported and braced with minimum 1 cross bar in top halo.
- F. Foot protection bar(s) required. Main cage may not be further forward than the rear of the engine.
- G. All bars forward of the cage must be lower than the hood.
- H. "X" OR "Z" BAR BEHIND THE DRIVER'S HEAD IS HIGHLY RECOMMENDED.
- I. All driver side door bars and uprights must be a minimum 1.75" and .095" wall thickness.
- J. Minimum 4 driver side door bars, parallel to the ground and perpendicular to the driver, and welded to the front and rear Roll cage.
- K. Passenger side must have at least 1 cross door bar, horizontal or angled, and 1 top door bar, minimum 1.5" O.D.
- L. Steel door plate, 16 gauge (.065") minimum thickness, must be securely welded to the outside of the driver side door bars and cover the area from top door bar to bottom door bar and from rear hoop down post to front cage down post.

5. FRONT SUSPENSION AND STEERING

- A. All components must be steel, unaltered OEM, in OEM location, and replaceable by OEM parts.

Suspension & steering Exceptions:

1. Tube type upper A- frames with or without aluminum or steel cross shaft.
2. Upper control arm mounts can be moved.
3. Stamped steel OEM replacement lower a-frames.
4. Rubber, nylon, or steel lower a-frame bushings; no offset bushings
5. Welded or bolted shock mounts on lower a-frames
6. Lower a-frames must be right and left, (Whittemore speedway will allow Mixing of lowers Ford / Chevy)
7. Lower a-frame mounts and bolt holes on frame must be in OEM location.
8. OEM or aftermarket steel ball-joints allowed.
9. Sway bar must be OEM type, no spline style bars.

10. Two-piece steel hub and rotor may be used. (No Aluminum Hubs)
11. All spindles must have a min of 3/16" stainless cable or NASCAR type tethers attaching to the hoop of the car.
12. No rack and pinion steering.
13. All steering components must be steel, OEM type, in OEM location.
14. Tie rod ends and adjuster sleeves may be replaced by a minimum .625" steel rod ends and steel tubes.
15. OEM spindles can be reamed for ball joints and modified to accept heim style outer tie rod ends.
16. Spindles May be modified for caliper mounting purposes only.
17. Bolt on or weld on spindle savers allowed.
18. Spindles arms must be the same length on both sides as measured from the center of the ball-joint pin to the center of the tie rod end bolt hole center.
19. Passenger car drop spindles allowed (OEM passenger car cast spindles ONLY. NO MADE FOR RACING OR FABRICATED SPINDLES.)
20. Spindles must be right and left, the same height and of the same make (Example- Pinto, Metric, and Chevelle etc.)
21. Steel steering shafts and knuckles only; steering quickener, steering wheel and quick release may be aluminum.
22. Driver compartment steering may be modified but must be kept on the left side.
23. Center-link must be steel and can be OEM, aftermarket or made for racing.

6. **SHOCKS**

- A. ONE shock per wheel.
- B. No external canister shocks (SCHRADER VALVES PERMITTED)
- C. Single adjustable shocks permitted.
- D. Double adjustable shocks or any type of blow off shafts not allowed.
- E. Bump Springs and Bump Stops are allowed.
- F. All shocks must be easily removable and uncovered.
- G. No Coil-overs allowed on front but may be used on the rear shocks.
- H. Bump sticks will be allowed in front or rear.
- I. One additional shock allowed in the lift/pull-bar area.

7. **SPRINGS**

- A. A. Steel coil and leaf springs allowed.
- B. Coil springs must be at least 4.5" O.D. and made of spring steel. (No exotic spring materials.)
- C. No torsion bars or air bags.

Spring Exception:

1. Pull bar and bump springs may utilize smaller O.D. springs.

8. **REAR SUSPENSION**

- A. No independent rear suspension.
- B. All components must be steel. (Aluminum hex tubes acceptable)

- C. Rear of frame may be altered to accept leaf or coil springs.
- D. Steel coil-over eliminators, and steel or aluminum (5") coil-over kits, are allowed on the rear only, and must conform to Shock and spring rules.

9. REAR END

- A. Any steel approved OEM passenger car or truck rear end allowed.
- B. Closed, steel tube Quick changes allowed.
- C. Floating steel safety hubs are mandatory.
- D. Axles must be made of steel.
- E. No cambered rear end tubes or snouts.
- F. One-piece drive flange only.
- G.** All components must be steel, other than listed below exceptions.

Exceptions

- 1. Lowering blocks
- 2. Axle caps
- 3. Rotor plates
- 4. Drive flanges
- 5. Third link bracket (Example - Sweet Style etc.)
- 6. No covers allowed on the rear of the body.
- 7. All cars running a birdcage type rear suspension must have a 1/16" steel plate or 1/8" alum plate behind the seat. The plate must attach from the top bar to bottom, and from the left side to right at least 3" past the seat.

10. WHEELS

- A. 8" steel wheels only, measured from inside of the bead to inside of the bead.
- B. No screws or rim mounted bleeder valves.
- C. Steel or aluminum wheel spacers are allowed.

11. TIRES

- A. Hoosier F70 tires only.
- B. No recaps.
- C. No softening, soaking, conditioning, siping, or grooving of tires.
- D. SOAKING OF TIRES IS PROHIBITED AND STRICTLY ENFORCED.

(see

Whittemore speedway race tire policy)

12. BRAKES

- A. MUST be steel OEM type only and operative on all 4 wheels.
- B. Must maintain minimum OEM dimensions for hub/rotor and calipers.
- C. Bolt pattern may be changed.
- D. Larger studs allowed.
- E. No hat style front rotors.
- F. Rear rotors may be aftermarket, minimum .810-inch-thick, vented rotors only.
- G. No scalloped or drilled rotors, front or rear.

13. EXHAUST

- A. A type of Mufflers is required.

14. FUEL SYSTEM AND FUEL

- A. Mechanical or belt driven pump only and must be mounted on front of motor.
- B. Racing fuel cell required with a 22-gallon maximum capacity, square or rectangle in shape.
- C. (No tear drop, wedge, or exotic F-1 type fuel cells allowed).
- D. Fuel cell must be in a minimum 22-gauge steel container.
- E. Cell must be securely mounted behind the rear axles and between the rear tires.
- F. Cell shall be mounted between frame rails and maintain a minimum 6" of ground clearance.
- G. Cell must be mounted with a minimum of 2 solid steel straps around the entire cell, 2" wide and .125" thick or equivalent.
- H. All cell mounts must be steel and securely welded or bolted to the frame.
- I. Fuel cell guard must cover rear of cell and extend past both ends of the cell.
- J. Fuel cell guard must extend below the bottom of the fuel cell.
- K. Vents and lids must have check valves.
- L. Fuel line pickup must be on top of cell.
- M. Racing gasoline or alcohol allowed. E85 will be allowed.
- N. CARS THAT RUN ALCOHOL MUST HAVE AN "A" ON BOTH OUTER SIDES OF SAIL PANELS

15. WEIGHT

Minimum total weight limit of 2,450 pounds with 1,000 pounds right side (No Tolerance) when car is on scales for tech, the driver must be sitting in a normal position, not leaning to manipulate left or right side percentage of weight, all driver equipment in driver's lap or on driver, including helmet, Hans etc. driver must have hands on steering wheel or hand's on helmet in lap, you will not be allowed to lean or grab bars in car, one warning, then lose a lap or session of qualifying)

- A. Weights must be securely mounted with at least two (2) half inch bolts to frame or roll cage and painted white with car Number on it.
- B. No weight outside of the body.
- C. No titanium, carbon fiber, or exotic materials used on race car.
- D. No gun-drilled, tubular, hollow bolts/studs. Steel fasteners only.
- E. A center section filled with weight ballast will be allowed.
- F. A center section filled with light material such as aluminum or lexan etc. that is riveted or bolted to act as a pan will not be allowed.
- G. A center section with weight trays that have thin steel welded from the chassis manufacture will be allowed.

16. BATTERY / STARTER

- A. One 12/16-volt battery only, must be securely mounted between frame rails, behind crossmember, in front of rear end and outside of driver cockpit with positive terminal covered.
- B. Car must have the capacity of starting without being pushed or pulled.

17. GAUGES / ELECTRONICS

- A. No electronic monitoring computer devices capable of storing or transmitting information.

Gauge / Electronics Exceptions:

- 1. Analog tachometer.
- 2. Lap timers allowed during practice only.
- 3. No adjustable ignition control boxes (excluding digital MSD rev limiter adjustment see #8)

4. One 12/16-volt ignition box allowed.
5. No additional ignition accessories allowed.
6. Distributor: No magnetos, distributors are allowed with only 1 pick-up wired for use.
7. No traction control devices.
8. Ignition box & wire harness can be removed and swapped out any time. Several MSD, JMS, Crane or Daytona ignition boxes are allowed. (The MSD ultra 6 AL or ultra 6AL plus ignition box's along with any ignition box that is App adaptable or has Bluetooth connectivity will not be allowed in competition at Owosso speedway.
9. No cell phones, smart watches, blue tooth devices ETC. in car or with driver, this will be an immediate DQ.

18. TRANSMISSION

- A. Must have at least two forward gears and one reverse, plus a neutral position.
- B. With engine running and car in still position, must be able to engage car in gear and move forward, then backward.
- C. OEM production type or approved aftermarket transmissions (Bert, Brinn, Falcon) allowed.
- D. No 5-speed or more transmissions. (2-speed, 3-speed, 4-speed and automatic allowed).
- E. No 'in and out' boxes allowed.
- F. Standard clutch type transmissions must have a blow-proof bellhousing (steel or aluminum).
- G. Automatic transmissions must have an approved scatter shield.

19. DRIVE SHAFT

- A. Minimum 2.0" diameter, steel drive shaft, painted white.
- B. Steel slip-yokes only.
- C. 360-degree protection of drive shaft hoop is required and must be constructed of at least .125 / 1/8" inch by 2-inch wide steel or equivalent, mounted 6" Back from front u-joint.

20. ENGINE COMPARTMENT

- A. Rear of engine must be mounted at least 72" forward from centerline of rear axle.
- B. Engine offset must be kept within 2" of centerline of front cross member with engine level.
- C. 11" crank height
- D. Radiator must be mounted in front of engine.
- E. Cooling system may be modified as needed.
- F. No antifreeze allowed.

21. ENGINE

- A. Any American make cast iron block engine allowed.
- B. No machine work to the outside of the block (lightening).
- C. Wet sump oiling system only.
- D. Single stage external pump allowed if oil remains in the pan (No external tanks).
- E. One naturally aspirated two- or four-barrel carburetor only. (No fuel injection).
- F. LS motors no coil packs, must have distributor.

22. NUMBERS / DECALS

- A. All numbers shall be a visible color, affixed to both doors, quarter panels and top of the roof, minimum size of 4 inches wide & 20 inches tall, must be identifiable from top or sides to track personnel for scoring purposes.

23. BUMPERS (See body diagrams/dimensions below for reference)

- A. Steel bumpers must always be Welded or bolted securely to the frame.
- B. Must be a minimum 1.25" O.D. tubing, .065" wall thickness.
- C. Aluminum I-Beam rear bumper is allowed.
- D. Two bar front bumper must be mounted frame end to frame end, no wider than width of OEM frame horns.
- E. Bottom loop must be parallel to the ground. Top bar must be directly above bottom bar, minimum 6.5" apart, measured Center to center.
- F. No sharp edges.
- G. Rear bumper must have rounded nerf bars that follow quarter panel and connect back to frame on both sides.
- H. Bumper must be same width of quarter panels.

24. BODIES: (See body diagrams/dimensions below for reference)

A. ROOF

1. You may run an aluminum roof if it meets the specs of a fiberglass roof.
2. **Roof Rake:**
 - a. (Must be a MINIMUM of 3" and MAXIMUM of 5" at the front).
 - b. (Must be a MINIMUM of 1.5" – and a MAXIMUM of 2" at the rear).
 - c. (All parts of the front and rear edges of the roof must fall between the maximum and minimum rake Dimensions)
3. Roof mounting must be within the body diagram measurements for roof rule Diagram (M).
4. ROOFS MUST BE FIBERGLASS OR ALUMINUM (NO CARBON FIBER) FULL SIZE, ROUNDED AND STOCK APPEARING (NO FLAT ROOFS).

B. INTERIOR

1. It is highly recommended that you keep the interior open in the cockpit around the driver in case of emergency.
2. The body must be the same width, front to rear, and parallel to the OEM frame.
3. Engine compartment must remain open on both sides.
4. Hood must be enclosed at rear.
5. No panel in front of the right door to engine compartment.
6. No inner panels.
7. Roof must attach to decking with A, B and C Pillars.
8. Driver and passenger side windows must have at least 12" X 18" opening (height and width), measured at the center of the window, between the lowest points at top of window, whether roof or roll cage, and the highest point at bottom of Window, whether interior or body.

9. No full windshields allowed.
10. Must have a minimum of 3 windshield bars in front of the driver.
11. Lexan or aluminum cowl panel in front of the driver can be no wider than the cockpit and no farther back than the Steering wheel.
12. Minimum .125" aluminum, or 22 (.035") gauge steel, complete floor pan required.

C. SPOILER

1. 4" x 66" maximum spoiler. (Lexan is recommended)
2. Must be 45° to deck lid.
3. Spoiler must be solid.
4. Braces may support from rear. Verticals of any kind or forward supports are not allowed.

D. SAIL PANELS

1. Must not be wider than the body and must attach to the quarters in a single stock appearing plane that angle inward to the roof.
2. No fins or lips on body, however, you may run a lip of 3/4" x 3/4" on sail panel for strength only.
3. May use Lexan in sail panels. (Must be used in both sides)
4. Quarter panels and B/C pillars must be 2 distinct pieces.

E. NOSES

1. Plastic noses are allowed if they meet body dimensions outlined below.
2. All cars must run a full upper and lower nose.
3. Noses will be allowed a maximum 3" front lower valance/splitter around the bottom of the nose.
4. Aluminum noses are allowed vertical sides with a maximum lip width of 1.5".

F. BODY MISC

1. No plastic body parts other than approved noses, hood scoops or rockers.
2. No wings, louvers, aerodynamic devices or lips inside or outside the car.
3. Outside of tires must be the widest part of car.
4. Oil coolers/radiator must not protrude above interior or outside of the body.
5. Pans under car, Nose, quarters, or right side of chassis to body will not be allowed.
6. You will be allowed a skid plate for oil pan, cannot be excessively bigger than oil pan, tech will have final say on skid plate size if problems occur.
7. A center section filled with weight ballast will be allowed.
8. A center section filled with light material such as aluminum or lexan etc. that is riveted or bolted to act as a pan will not be allowed.
9. A center section with weight trays that have thin steel welded from the chassis manufacture will be allowed.
10. All weight, body, and height measurement with driver in the car.

BODY DIMENSIONS

- A. 20" Max. – 16" Min. (Ground to center of bumper front & rear)
- B. 6.5" Min. (Center to center)

- C. 46" Max. – 42" Min.
- D. 6" Max. Hood sides – 3" Max. Rake in hood.
- E. 36" Max. Dimension applies to bumper and nose length and includes 3" splitter.
- F. 6" Max. (Scoop/Deflector)
- G. Side skirts can hang no lower than the bottom plane of the frame. – Bottom of Quarters must be 8" from ground.
- H. 19" Max. (Same both sides)
- I. 112" Max. – 108" Min.
- J. 29" Max. – 22" Min.
- K. 72" Max. Or not past back of block, right side. Left side may extend forward to cover foot box if necessary.
- L. 18" Max. – 12" Min. Opening, both sides.
- M. With a 6' level, you must have a minimum of 1.5" and a maximum of 2" of gradual clearance at the rear edge of the Roof and 3" minimum and 5" maximum at the front edge of the roof. The rake of the roof may be measured at any Point from side to side.
- N. 117" Max. – 106" Min.
- O. 45" Max. – 34" Min.
- P. 3" Max. Height at rear of sail panel with a gradual slope from the roof to this point.
- Q. Interior rake is 6" Maximum front to rear and flat across.
 - 11. If flat at front half of interior, you have used up 50% of your 6" so from behind the driver to the rear you only have 3" of available slope remaining.
 - 12. Top of interior must be flush with the top of doors and quarter panels.
 - 13. Interior rake measurement will be the difference in height between the top, front edge of the door and the highest point of the rear quarter panel.
- R. 38" Max. – 28" Min.
- S. 38" Max. – 24" Min.
- T. 66" Max. – 24" Min. No narrower than radiator
- U. 52" Max. – 44" Min.
- V. 56" Max. – 41" Min.
- W. Tires must be the widest part of the car. Must be able to see sidewall of tire from front, top, and rear.
- X. 66" Max. – 53" Min.
- Y. Rear panel must be solid 8" tall, no louvers, 90 degrees to the ground & securely attached / fastened to be flush with rear edge of qtr. panels & deck lid.

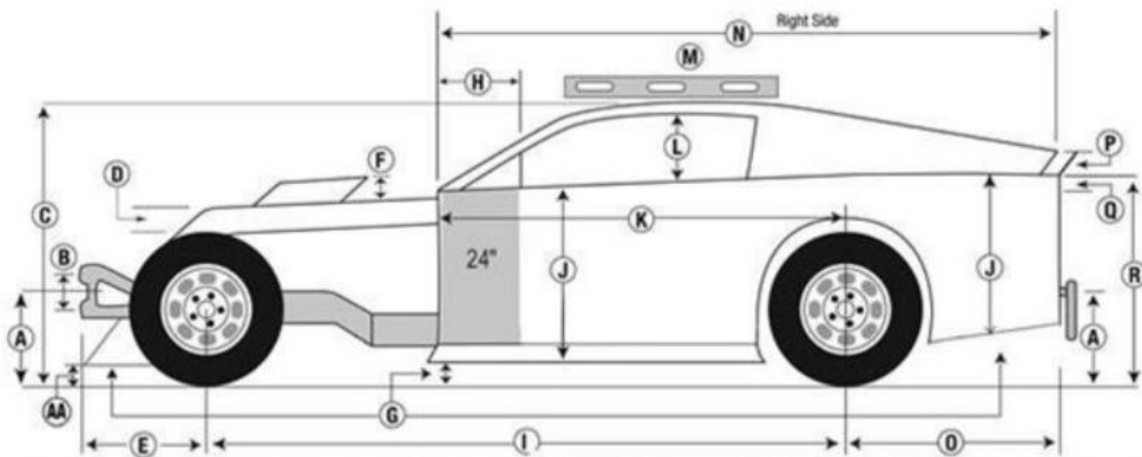

Shaded area reserved for Series and/or Track Sponsor Decals. MUST DISPLAY DECALS TO BE ELIGIBLE FOR FULL PURSE.

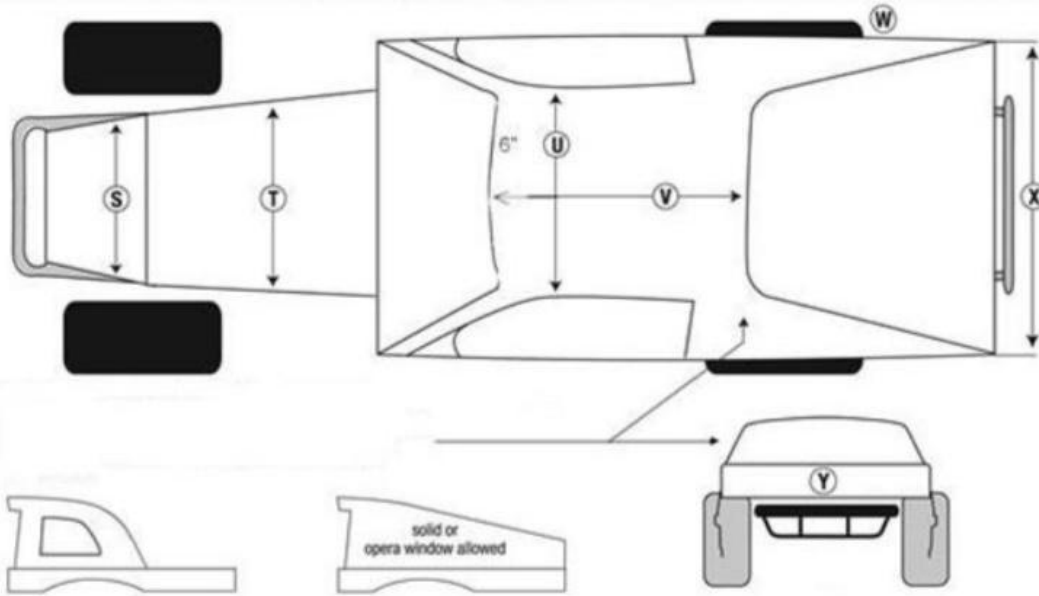

25. OVERALL:

- A. Whittemore speedway reserves the right to change, modify, add to, or delete these rules as they deem necessary.
- B. Whittemore Speedway reserves the right to confiscate any part or parts deemed by their Officials to be outside the rules. This includes tires, or any other part(s) of any race car, at any event, at any time.
- C. All decisions of the Officials are final and binding without exception.

26. GENERAL COMPETITION:

- A. Drivers shall be responsible for the conduct and actions of all crewmembers, and any unsportsmanlike conduct shall be grounds for disqualification or punitive action as determined by Sanctioning Body and/or Track.

- B. Sanctioning Body and/or Track shall have the authority to disqualify members and assess fines.
- C. All discussions with Officials shall be conducted in a professional manner and at a proper distance.
- D. Drivers under the age of 18 must produce a signed and notarized Parental Consent form by Parent or Legal Guardian.
- E. Sanctioning Body and/or Track may require, at its option, any competitor to undergo a physical or drug testing before said individual can compete.
- F. MODS if you are .5 seconds or more slower than fast qualifier you will be moved to the rear of the field.
- G. MODS will invert with 12 or more cars. Invert will be roll of one die plus 6 by the Fast Qualifier.

27. WHITTEMORE SPEEDWAY RACE TIRE POLICY & INSPECTION PROCEDURE

1. Tire tampering to soften or enhance tire performance, will carry strict penalties
2. All Hoosier or DOT tires in competition at Whittemore Speedway will have a solvent sensitive stamp or be significantly internally powdered to indicate if solvents were used in or on the tire.
3. All Classes Hoosier and DOT “except” (outlaw super late models) race tire policy & inspection procedure. Tampering or softening tires with chemicals or solvents is not allowed.
 - a. This rule applies to all Hoosier or DOT impound or non-impound tires in the pits, on the car, in the trailer, in the hauler, etc. “ALL tires”
 - b. All Tires may be checked at any time.
 - c. A race team that uses a tire other than the designated tire allowed / approved per your specific class rules will automatically receive an offence for tire tampering.
 - d. No softening, soaking, conditioning, siping, grooving, to enhance performance of race tires.
4. Testing procedure for race tires is as follows:
 - a. Tire(s) will be collected after feature event.
 - b. Tire(s) will be cleaned in the area of officials choosing. Cleaning will be done by the team with the teams own cleaning tools.
 - c. Cleaned tire inspection area will be heated with heat gun, to the temp of 200* Fahrenheit and then checked with a durometer.
 - d. Tire durometer will be used to determine what tire / tires will be sampled and sent to laboratory for testing.
 - e. When tire samples are sent to the lab, all Winnings and points will be frozen until results are received.
 - i. Final lab results that produce a failed sample inspection, no winnings or points will be awarded, and the team will receive their discipline for tire tampering.
 - ii. Final lab results that produce a clean un-failed tire sample inspection, upon receiving cleared inspection results from laboratory, all winnings held will be rewarded.
 - f. Tire samples can be taken at any time, before, during, or after the event.
 - g. Tire Samples will be put in an evidence vial per Blue Ridge Laboratories Inc. & then sealed in an evidence bag and sent to: Blue Ridge Laboratories Inc., 2766 Blue Creek Road, Lenoir, NC 28645.
 - h. Whittemore Speedway will tag all sampled tires with a serial number cable tag.

*Whittemore speedway will retain all tires sampled till tire sample results are received.

*Whittemore speedway will not return any tire / tires to a race team if they produce failed test results, a tire that produces a failed test result will become Whittemore speedway property, race team has no option to redeem it.

*Whittemore speedway will return all tires that produce a clean or passing test result to the race team.

*Whittemore speedway will not be liable for or replace any tires that test samples are taken from, Regardless of tire or tires testing / sample results.

*Whittemore speedway will award race team with a D.Q. for failed tire sample results, further discipline depending on the severity of the tire tampering violation is at the discretion of Whittemore Speedway officials, all decisions are final and cannot be appealed or protested.

28. Conduct or Behavior Zero Tolerance

- A. Whittemore Speedway officials have a zero-tolerance policy for unnecessary events that take place anywhere on Whittemore Speedway property, on track or in the pits, such as but not limited to:
- B. Arguments.
- C. Unnecessary behavior of any kind.
- D. Intentional / Aggressive contact between cars on track, during a caution will not be tolerated, the driver or driver's intentionally making contact with another race car under caution will receive the black flag, you will not be scored & sent to their pits.
- E. Vulgar language.
- F. Threatening other racers, teams, help or family.
- G. Going to another race teams pit to argue.
- H. Unnecessary speed in pits with your race car.
- I. Bumping others race cars with your race car in pits expressing your anger.
- J. Unnecessary actions toward Whittemore Speedway officials, about tech decisions or on track decisions.
- K. DRINKING OF ALCOHOL IN PITS BEFORE RACE NIGHT IS FINISHED, AUTOMATIC DQ
- L. If security is called, fines, penalties or discipline is to the discretion of Whittemore speedway officials.
- M. If argument or unnecessary actions continue, fines, penalties or discipline is once again, to the discretion of Whittemore speedway officials.

THE ABSENCE OF A PARTICULAR RULE DOES NOT SUBSTANTIATE ITS APPROVED FOR COMPETITION

WHITTEMORE SPPEDWAY OFFICIALS, DECISION IS FINAL ON ALL RULES & DECISIONS

* RULE INFRACTIONS PER CLASS OR GENERAL RULES.

* OCCURANCES ON TRACK OR IN PITS.

* NOT OBEYING THE DIRECTION OF RACE CONTRIOL.

NO DECISION WILL BE APPEALED OR REVERSED - ARGUMENTS WILL NOT BE TOLERATED!!